

MODEL 8513

INDUSTRIAL COMPLIANCE METER

for Electromagnetic Energy

CE

OPERATIONS MANUAL



Table of Contents

CHAPTER 1 INTRODUCTION	3
About Your Model 8513	3
Equipment Supplied	3
Specifications	4
CHAPTER 2 UNDERSTANDING YOUR MODEL 8513	5
General Description	5
Audio Alarm	5
ATE Test Jack	6
Probe	6
Battery	7
Display	7
Keyboard	8
CHAPTER 3 GETTING READY	9
Introduction	9
Connecting the Probe	9
Determine the Frequency of the Emitter that You Plan to Measure	9
CHAPTER 4 MAKING A MEASUREMENT	11
Introduction	11
Getting Started	11
Entering the Frequency Range	11
Zeroing the Meter and Probe	12
Changing the Field	13
Units of Measure	14
Maximum Hold	15
Probe Overload and Range Overload	15
Bar Graph Ranges	16
Battery Status Indicator	18
Turning the Meter Off	18
CHAPTER 5 MAINTENANCE	19
General	19
Calibration	19
Battery	20
APPENDIX MEASUREMENT TECHNIQUES	21
Introduction	21
Obtaining a Reading	21
About Measurement Surveys	22
Measuring Industrial Equipment	23
Precautions	23
Measurement Uncertainty	24
INDEX	25
WARRANTY	26
ABOUT NARDA SAFETY TEST SOLUTIONS	27

Chapter 1

INTRODUCTION

About Your Model 8513

Your 8513 is a combination hand-held, battery-powered meter and dedicated dual field (electric and magnetic) probe. This instrument is designed to simplify the measurement of electromagnetic fields, especially around industrial and medical equipment.



Equipment Supplied

Your Model 8513 is supplied with

- ◆ Meter
- ◆ Probe
- ◆ Battery, 9 Volt alkaline
- ◆ Storage Case (P/N 32542708)
- ◆ Operations Manual (P/N 42985300)

Specifications

Model	8513
Frequency Range Bands^a	10 to 42 MHz Three: 10-20 MHz, 20-35 MHz, & 35-42 MHz
Measurement Range	Single Range, 0.05 to 50.0 mW/cm ² Bar Graph Auto Ranges or Select One of Three 10 dB (10:1) Ranges
Display Type Digital Output Bar Graph Units	Custom Liquid Crystal Display 3½ Digits, .44 inch (11 mm) Character Height 18 Segments Custom Legends
Controls	8 Key Membrane Keypad
Zeroing	One Touch Auto Zero
Units	mW/cm ² , W/m ² , V/m, A/m
Audible Alarm	Probe Overload Warning
Accuracy (frequency response and meter)	Calibrated precisely at three ISM frequencies. Accuracy at other frequencies within each of the three user-selectable frequency bands is ±0.75 dB for the E field and ±1.0 dB for the H field, plus one digit ^b .
Isotropic Error (max)	±1.00 dB
Ellipse Ratio (max)	±0.75 dB
Calibration Frequencies	13.56 MHz, 27.12 MHz, 40.68 MHz
Calibration Accuracy	±0.5 dB
Probe Overload	>50 W/cm ²
Battery Type Life (approx)	9V alkaline 50 Hrs.
Weight Meter Probe	1.35 lbs. (0.61 kg) 0.60 lbs. (0.46 kg)
Size (LxWxD) Meter Probe Cable (approx)	7.8" x 2.5" x 1.8" (19.8 cm x 6.4 cm x 4.6 cm) 16 inches (41 cm) long 44 inches (112 cm) long
Temperature Operating Non-operating	-20°C to +50° -20°C to +70°C
Humidity	0% to 90%, Non-Condensing
Accessories Supplied	Battery, Manual, Shielded Storage Case ^c

NOTES

- ^a The probe always detects energy over its entire measurement range. The "bands" are used to provide greater accuracy by automatically compensating for frequency response deviation.
- ^b There is an additional uncertainty due to traceability, i.e. the fields generated to calibrate the Model 8513 are accurate within +/- 0.5 dB.
- ^c The heavy duty storage case is foam-lined and shielded to protect the meter and the probe in storage and in transit. It is approximately 17.6 in X 12.6 in x 5.0 in (44.7 cm x 32.0 cm x 12.7 cm). The case weighs approximately 9 lbs. (4.1 kg).

Chapter 2

UNDERSTANDING YOUR MODEL 8513

General Description

It is important to be familiar with the Model 8513 instrument before you use it. This chapter includes descriptive data keyed to highlighted illustrations to help you locate the various features of the instrument. The descriptions not only identify the features but tell you how to use them.

Audio Alarm

Your Model 8513 is equipped with an audible alarm that emits sound through a tiny hole on the bottom of the meter. The alarm sounds whenever the field strength exceeds its full scale measurement range (Probe Overload). It is also used to signify other situations such as certain keystrokes, the completion of the zeroing function, and an over-range condition (which can occur if one of the two more sensitive bar graph ranges is selected).

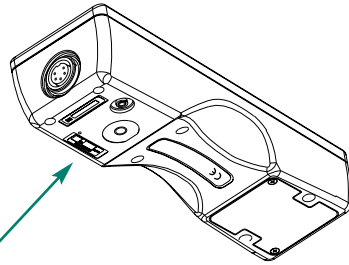

ATE Test Jack

The small jack on the bottom of the meter is used by Narda to test and calibrate the meter using proprietary software and automatic test equipment (ATE).

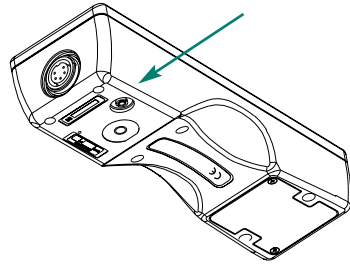

Probe

Both the meter and the probe components of the Model 8513 are required to make measurements. The probe contains two sets of three sensors. One set of sensors is used to detect the electric field and the other set is used to detect the magnetic field. These three sensors make the probe responsive to energy from all directions. This is known as an *isotropic* (omni-directional) probe.

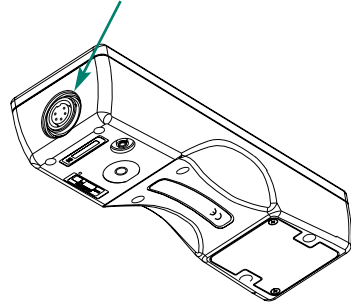

NOTE

There is no need to disconnect the meter from the probe. You can store the entire assembly in the case when it is not in use. The only time it is necessary to disengage the connector is during calibration and repair.

Battery

The 8513 operates for approximately 50 hours from a standard 9 Volt alkaline battery when used an average of 2-4 hours per day.

The battery is accessed by loosening the two screws on the bottom of the meter and removing the battery cover.

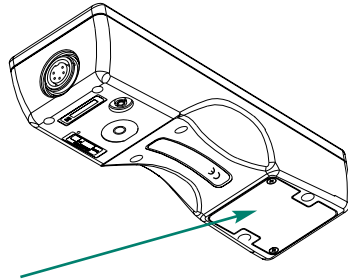

Display

The liquid crystal display (LCD) has a 3¹/₂ digit numerical display, an 18-segment bar graph that indicates relative field strength, five arrows that indicate field strength, and several special legends. The legends include the units of measure, the words "ZERO", "MAX", and "AUTO" plus a battery status indicator.

Just below the display area are two boxes that indicate whether the electric field or the magnetic field is being measured. Above the display are three more boxes that indicate which frequency range the meter is set for. One field arrow and one frequency range arrow will always be illuminated when the meter is in use.

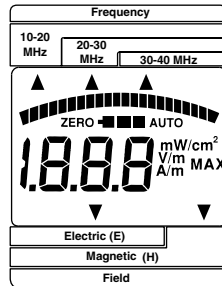

Keyboard

The Model 8513 has eight keys:

Max Hold Toggles the digital readout between an instantaneous readout and a display of maximum value. (The bar graph continues to function as an instantaneous display.)

Units Changes the unit of measure.

Freq The **Freq** (frequency) key sets the meter to compensate for any error in the probe so that the measured value displayed is as accurate as possible. It eliminates the need for using "Calibration or Correction Factors".

E/H Field Used to select measurement of the electric field (E) or the magnetic field (H).

Auto Zero Enables you to automatically zero the meter and probe.

Range Locks in a specific measurement range for the bar graph. **The digital display is not affected.** The meter automatically displays a digital value over the probe's entire measurement range. See *Bar Graph Ranges* in Chapter 4.

On Turns the meter *On*.

Off Turns the meter *Off*.

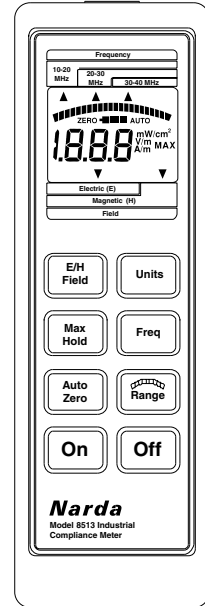

Chapter 3

GETTING READY

Introduction

This chapter will help you get ready to take measurements with your Model 8513.

Connecting the Probe

It is recommended that you never disconnect the meter from the probe and store the entire assembly in the case when it is not in use. The only time it is necessary to disengage the connector is during calibration and repair. If required, the probe can be connected to the meter by aligning the "notch" on the male connector on the end of the cable with the notch on the female connector on the top of the meter. Insert the connector and securely tighten the retaining nut to insure a good connection is made.

Determine the Frequency of the Emitter that You Plan to Measure

The single most important thing that you must do prior to making any measurements is to determine the operating frequency of the emitter or emitters that will be surveyed for electromagnetic radiation field levels. The frequency of the emitter(s) must not be lower than 10 MHz nor higher than 42 MHz - the rated frequency range of the 8513.

Chapter 4

MAKING A MEASUREMENT

Introduction

This chapter will help you make measurements with your Model 8513. Information is included for turning the meter on, zeroing, understanding the display screen, and using the options controlled by the keyboard.

Getting Started

Press the **ON** power key. The enunciator will sound a double beep, all LCD segments will turn on briefly and then the version number of the firmware (internal software) will be displayed briefly. After a few seconds, the display screen will show a battery symbol that indicates its status plus a flashing arrow opposite the frequency range that includes the frequency of the last emitter measured.

Entering the Frequency Range

The flashing arrow indicates the frequency range last measured with the instrument.

1. If you want to measure an emitter with an operating frequency that is within the same range, press the **Freq** key once. The arrow will stop flashing indicating that the meter has again been set to the same frequency range. The word **ZERO** will begin to flash.
2. If you want to measure the emissions from an emitter with an operating frequency outside this range, press the **Freq** key again. Each time you press the **Freq** key, the arrow will move to a different frequency range. Continue to press the **Freq** key until the arrow is below the frequency range you intend to measure.

Zeroing the Meter and Probe

The probe and meter must be "zeroed" together. It is important that the probe is not exposed to substantial radiated fields ($>0.005 \text{ mW/cm}^2$ or 4 V/m) during the zeroing process. Most office environments are well below this level. The storage case is shielded and provides a convenient "zero density" environment. Alternately, completely wrap the head of the probe in aluminum foil during zeroing. It is also important that the meter and the probe be zeroed when both are at the same temperature.

To zero the instrument...

1. Place the probe in the storage case.
2. Press the **Auto Zero** key. The internal temperature of the meter is displayed briefly. The word **ZERO** will stop flashing. The zeroing process takes about four seconds.
3. After zeroing is completed, the audio alarm will "beep" once and the measurement screen will appear. You will see a digital display with a unit of measure (mW/cm^2 is the default setting upon turn-on). Depending on the intensity of the field, you may also see some deflection on the bar graph.

If the instrument cannot be zeroed, the word **ZERO** will continue to flash and the audio alarm will beep several times. The most likely reasons why the probe could not be zeroed are:

- ◆ *The probe is not connected properly.* Check the connector and retry.
- ◆ *The field strength is not low enough.* Move away from the source of energy and use the storage case to zero the system.
- ◆ *The equipment is damaged.*

To reconfirm the zero while the instrument is in use (after it has already been zeroed)...

1. Establish a zero density environment for the probe as before.
2. Press and hold the **Auto Zero** key for about half a second until a second beep is heard. This will begin the auto zero cycle that will automatically "touch up" the zero and correct for any drift that may have occurred in the meter and probe combination. (The half second delay is built in to reduce the chance of accidentally initiating an auto zero sequence).

Changing the Field

Measuring the field strengths around equipment that operates in the 10 MHz to 42 MHz frequency range that the 8513 is designed for will invariably mean that measurements are being made in the "near field". In the near field, the electric field and magnetic field components do not have a precise relationship and can vary widely over small distances. This means that both the electric field and the magnetic field must be measured **separately** and **accurately**. (See *Measurement Techniques in the Appendix*).

The probe of the 8513 contains two sets of sensors. One set of three sensors is used to measure the electric field. The second set of three sensors is used to measure the magnetic field. These three sensors for each field make the probe responsive to energy from all directions. This is known as an **isotropic** (omni-directional) probe.

CAUTION

The 8513 is set to measure the electric (E) field upon turn-on. Health experts generally agree that the electric field component of an electromagnetic wave has more affect on the human body than the magnetic (H) field and many of the newest standards allow higher exposure limits for magnetic fields than for electric fields. Therefore, always measure the electric field first.

Once you have measured the electric field, press the **E/H Field** key once to select the magnetic (H) field. The arrow on the bottom of the display will point to magnetic (H) field. Every time the **E/H Field** key is pressed the instrument will change (toggle) the field being measured.

Units of Measure

The **Units** key is used to change the units of measure. Only units of measure appropriate to the field being measured are available. The meter is set to read in mW/cm^2 upon turn-on. The **Units** key is used to cycle through the available options. Press the **Units** key once to get W/m^2 . Press it again to get either V/m (electric field) or A/m (magnetic field). If either mW/cm^2 or W/m^2 is selected and the **E/H Field** key is pressed to change the field being measured, there will be no impact on the unit of measure. If V/m (Volts per meter) is selected as the unit of measure for the electric field, pressing the **E/H Field** key will not only change the field type being measured but will also automatically change the unit of measure to A/m (Amps per meter). The table below shows the available units of measure:

Electric Field

mW/cm^2
 W/m^2
 V/m

Magnetic Field

mW/cm^2
 W/m^2
 A/m

Maximum Hold

The maximum hold feature changes the digital readout to a display of maximum value. The bar graph continues to function as an instantaneous display. Use the **Range** key to control the operation of the bar graph (see *Bar Graph Ranges*)

Press the **Max Hold** key to activate the maximum hold feature. The legend **MAX** will illuminate on the display to the right of the unit of measure.

Press the **Max Hold** key again to release the maximum hold feature and return to the normal, instantaneous measurement mode. This also clears the maximum hold value.

Probe Overload and Range Overload

The Model 8513 is designed to protect the probe and the operator from very high fields by providing a warning when either the frequency range of the probe is exceeded and/or one of the fixed bar graph ranges is exceeded. See *Bar Graph Ranges* on page 16.

A "Probe Overload" is indicated by a continuous sounding of the audio alarm and the digital display flashing "**O-L**" (**OverLoad**).

A "Range Overload" can occur when the bar graph is set to one of the two more sensitive ranges. Under such a condition the digital display continues to show a correct value while the bar graph is fully illuminated. The audio alarm beeps twice at the moment the range of the bar graph is exceeded. See *Bar Graph Ranges*.

Bar Graph Ranges

The bar graph has 18 divisions. The **Range** key is used to control how the bar graph displays information. The **digital display is not affected** by the **Range** key. The meter always automatically displays a digital value over the probe's entire measurement range. There are four available bar graph range settings: **AUTO** and three fixed ranges.

The default setting upon-turn on is the **AUTO** range which you will probably find convenient to use most of the time. Under a few conditions you may find one of the three fixed ranges useful. The following table illustrates how the range setting will affect the bar graph. The full scale rating of the

Range	Measurement Range
AUTO	As the level increases, the bar graph automatically switches between three ranges: 0.05 to 0.5, 0.5 to 5, and 5 to 50 mW/cm ² . Since there are 18 bar graph segments, the minimum value that will be displayed on the bar graph is about 1/18 of the full scale setting.
50 mW/cm²	3.0 to 50 mW/cm ²
5 mW/cm²	0.3 to 5 mW/cm ²
0.5 mW/cm²	0.03 to 0.5 mW/cm ²

If W/m² is selected as the unit of measure, the meter will operate in a similar manner. The only difference is that the ranges will be ten times higher (1 mW/cm² = 10W/m²).

The **Range** key is not functional when either V/m or A/m is selected as the unit of measure. The bar graph has a single fixed range of 0-434 V/m or 0-1.15 A/m.

To determine the current bar graph range setting...

1. Press and release the **Range** key. The measurement screen will disappear. If the meter is in the automatic range mode, the legend **AUTO** illuminates. If the meter is set to one of the fixed ranges, the screen shows either 50 mW/cm², 5 mW/cm², or 0.5 mW/cm².
2. If the range setting is correct, simply wait about 1¹/₂ seconds and the measurement screen will reappear.

To change range settings...

1. Press the **Range** key. The measurement screen will disappear and the screen will display the current range setting.
2. Press the **Range** key again before the measurement screen reappears (within five seconds). A new range will be displayed. Continue to press the **Range** key until you get the desired bar graph range.
3. The measurement screen will reappear about 1¹/₂ seconds after the last key stroke.

Battery Status Indicator

The battery status indicator consists of three sections that form the shape of a typical battery. The number of battery sections that are illuminated indicate how "full" the battery is. This is only a relative indication that should be compared to the expected life of the battery, which varies with the average use time. The relative remaining battery capacity is:

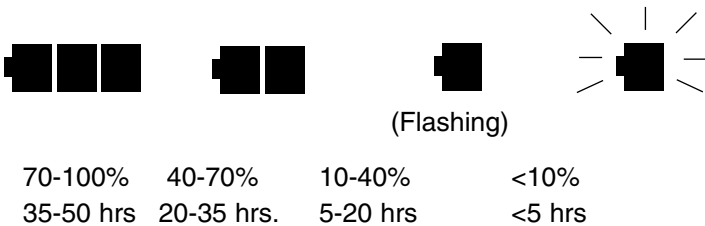

When the indicator has decreased to one segment in length and begins to flash, the battery has about 10% of its life remaining and should be replaced as soon as possible.

Turning the Meter Off

The meter is turned off by pressing the **Off** key and holding it down for about half a second (The delay is built in to reduce the chance of accidentally turning the meter off).

Chapter 5

MAINTENANCE

General

The Model 8513 requires very little maintenance. There are no operator adjustments required. The electronic circuitry is housed in a very rugged aluminum housing. This housing is not watertight and should not be immersed in water. The LCD display, the case, and the probe may be cleaned using a damp cloth.

Calibration

The Model 8513 is calibrated before it is shipped. Narda recommends that the Model 8513 be calibrated annually and will perform this calibration for a nominal charge.

Battery

A standard 9 volt alkaline battery will power the 8513 meter for approximately 50 hours (when used an average of two to four hours per day). The three-section battery status indicator gets shorter as the battery's energy is used. When the indicator has decreased to one segment in length and begins to flash the battery has about 10% of its life remaining and should be replaced as soon as possible.

The battery is located in a compartment in the lower part of the back of the meter. The battery compartment cover is held in place with two small screws that are held captive to the cover. To replace the battery...

1. Loosen the two screws and remove the cover.
2. Remove the battery and disconnect the battery clip.
3. Connect the new battery and place it in the compartment.
4. Replace the cover and tighten the two screws.

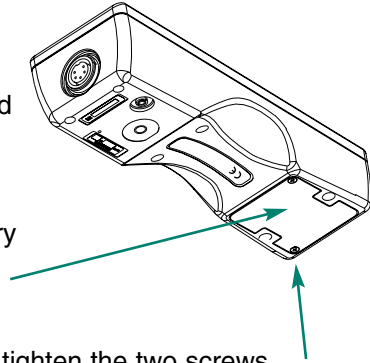

Any standard 9 volt alkaline battery can be used. Two examples are the Eveready No. 522 and the Duracell DA146.

Appendix

MEASUREMENT TECHNIQUES

Introduction

This appendix contains some general information about measurement survey, precautions you should observe when making measurements, and information on measurement uncertainty.

Obtaining a Reading

A reading is obtained by holding the Model 8513 meter in one hand and the probe in the other. Begin making measurements with the meter set for the electric field.

CAUTION

The 8513 is set to measure the electric (E) field upon turn-on. Health experts generally agree that the electric field component of an electromagnetic wave has more affect on the human body than the magnetic (H) field and many of the newest standards allow higher exposure limits for magnetic fields than for electric fields. Therefore, always measure the electric field

As you approach the source, observe the bar graph and measured value of signal strength on your meter. If you know where the source of energy is, point the probe towards it. If you do not know where the source is located or there are multiple sources, hold the probe above your head pointed up at about 45 degrees above the horizontal. Rotate the probe in a circle to find the direction where the maximum indication is obtained. The bar graph is a useful tool in obtaining the maximum indication.

About Measurement Surveys

When you perform surveys it is important that you observe a few guidelines to insure accurate readings.

- ◆ Make sure you scan the probe through the field to obtain a maximum reading.
- ◆ Keep the arm holding the probe extended out from your body as far as practical with the probe pointed towards the source of radiation.
- ◆ Measurements of the *electric field* from low frequency antenna systems (<50 MHz) often require special techniques because the human body acts as a scatterer that introduces errors. The best measurement technique when making measurements near antenna systems is to place the probe next to the meter on a non-metallic stand such as a wooden ladder or cardboard box. Then, stand back and read the meter without touching it.
- ◆ The human body has far less affect on magnetic fields. Therefore, these special measurement techniques are far less critical for magnetic fields than they are for electric fields.
- ◆ The minimum measurement distance between the surface of the probe head and the radiation surface should be about four inches (10 cm). Readings obtained with the probe closer to conductive objects than this distance can be inaccurate.

Measuring Industrial Equipment

When using the 8513, the main objective is often to quantify the magnitude of any potential leaks that might exist around industrial or medical equipment. When measuring around industrial equipment...

1. It is not necessary to use an insulated stand. Using the guidelines on page 22, you can hold the meter and probe as appropriate to find any potential leaks.
2. When you find a significant reading (leak) near the equipment, take note of the magnitude of the reading. Continue to hold the probe in the same position and press the **E/H Field** key. Take note of the magnitude of the magnetic field in the same location.
3. Continue to measure the magnetic field by scanning it through the field. At these frequencies (10-42 MHz) you will invariably be in the near field and a location where the electric field is high will often have a low level magnetic field and vice versa.
4. An equipment diagram is a useful tool that helps document the results of survey.

Precautions

When making measurements of electromagnetic fields, a potential exists to expose yourself to excessive levels of electromagnetic energy. Approach the source of energy slowly and begin making measurements from a distance that is known to have low levels of electromagnetic energy present. ***Be prepared to evacuate the area immediately if excessively high levels are observed.***

Measurement Uncertainty

The uncertainty of any measurement includes several factors:

- ◆ The 8513 is calibrated precisely at three ISM (Industrial, Scientific, and Medical) frequencies: 13.56 MHz, 27.12 MHz, and 40.68 MHz. There is essentially *zero frequency response error* when measuring equipment operating at any of these three frequencies providing that you select the correct frequency range using the **Freq** key as described in Chapter 4. The maximum uncertainty anywhere else within the selected frequency range is ± 0.75 dB for the electric field and ± 1.0 dB for the magnetic field. Since the meter and the probe are calibrated together, any small error contributed by the meter is compensated for during the calibration process.
- ◆ *Ellipse ratio* is ± 0.75 dB ($\pm 19\%$). The ellipse ratio is the ratio of readings that occur when one rotates the probe around the axis of its handle. Narda calibrates its probes by rotating the probe about its axis and using the mean value for the correction factor. If you rotate the probe around its axis and use the mean value, ellipse ratio can be eliminated as a source of uncertainty.
- ◆ *Isotropic* response is the error that occurs when the probe is pointed in different directions. It includes the ellipse ratio plus some additional uncertainties.
- ◆ Although the probe picks up energy from all directions, it is most accurate when pointed at the source of energy. In general, the isotropic response is no greater than the ellipse ratio providing that the probe is pointed towards the source of energy.

A good rule of thumb is that the total uncertainty is about ± 1.5 dB when the correct frequency range is selected and the probe is pointed at the source of energy. The uncertainty is reduced to ± 0.5 dB when the source(s) being measured operates at one of three ISM frequencies. (The 8513 is calibrated at these three ISM frequencies).

Index

- Alarm, Audio, 5
- ATE Test Jack, 6
- Auto Zero**, key
 - Description, 8
 - Using, 12–13
- Battery**
 - Changing, 20
 - Status Indicator, 18
 - Type, 7, 20
- Calibration, 19
- Display (LCD)**, 7
- Electric Field, 13
- E/H Field**, key
 - Description, 8
 - Using, 13-14
- Equipment, 3
- Industrial Equipment
 - Measuring, 23
- Keyboard, 8
- Magnetic Field, 13
- Max Hold**, key
 - Description, 8
 - Using, 15
- Off**, key
 - Description, 8
 - Using, 18
- On**, key
 - Description, 8
 - Using, 11
- Maintenance, 19
- Probe
 - Connection, 9
 - Description, 6
 - Field Type, Selecting, 13
 - Overload, 15
 - Zeroing, 12
- Range**, key
 - Description, 8
 - Using, 16
- Ranges
 - Bar Graph, 16
 - Probe Overload, 15
- Surveys
 - Measurement, 22
 - Measurement Uncertainty, 24
 - Obtaining a Reading, 21
 - Precautions, 23
- Units**, key
 - Description, 8
 - Using, 14
- Units of Measure, 14

Warranty

Narda Safety Test Solutions (Narda STS) warrants each product of its manufacture to be free from any defect in material and workmanship for a period of one year from date of shipment to, and return by, the original purchaser. All warranty returns, however, must first be authorized by a factory office representative.

The limit of liability under this warranty shall be to repair or replace any product, or part thereof, which proves to be defective after inspection by Narda STS. This warranty shall not apply to any Narda STS product that has been disassembled, modified, physically or electrically damaged or any product that has been subjected to conditions exceeding the applicable specifications or ratings.

Narda STS shall not be liable for any direct or consequential injury, loss or damage incurred through the use, or the inability to use, any Narda STS product.

Narda STS reserves the right to make design changes to any Narda STS product without incurring any obligation to make the same changes to previously purchased units.

This warranty is the full extent of obligation and liability assumed by Narda STS with respect to any and all Narda STS products. Narda STS neither makes, nor authorizes any person to make, any other guarantee or warranty concerning Narda STS products.

About Narda Safety Test Solutions

Narda Safety Test Solutions is the new name for the world leader in non-ionizing radiation safety equipment. In February 2000, Narda – an L-3 Communications Company – acquired the Safety Test Solutions business from Wavetek Wandel & Goltermann. To give more focus to the RF safety business and to separate it from Narda's other business in components and networks, a new division was formed – Narda Safety Test Solutions. It combines the complementary product lines and expertise of these two businesses. The company holds more than 95% of the patents in the field. Products are available to accurately measure electromagnetic fields from a few Hertz to over 100 GHz plus static magnetic fields. RF personal monitors cover 100 kHz to 100 GHz and area monitors detect energy from 300 kHz to 100 GHz.



USA: 435 Moreland Road
Hauppauge, NY 11788
Tel 1-631 231-1700 **Fax** 1-631 231-1711
E-Mail NardaSTS@L-3COM.com
www.narda-sts.com

GERMANY: Sandwiesenstrasse 7
D-72793 Pfullingen
Tel +49-7121-9732-777 **Fax** +49-7121-9732-790
E-Mail support@narda-sts.de
www.narda-sts.de