

MODEL 8715

ELECTROMAGNETIC RADIATION SURVEY METER

OPERATIONS MANUAL



Specifications

Model	8715
Display Type Digital Output Bar Graph Units	Custom Liquid Crystal Display 3 1/2 Digits, .44 inch (11mm) Character Height 18 Segments Custom Legends
Controls	8 Key Membrane Keypad
Inputs	Probe Cable Input
Zeroing	One Touch Auto-Zero
Measurement Range	Single, 30 dB Dynamic Range Bar Graph Auto Ranges or Select One of Three 10 dB Ranges Compatible with Narda 8700 probes ^a
Units	mW/cm ² , W/m ² , V/m, A/m, and Percent of International Standards
Audible Alarm	Probe Overload Warning Variable Alarm from 1% to 100% of scale
Spatial Averaging	For intervals up to 20 seconds. Averages 40 samples per second.
Time Averaging	Timer shuts off automatically after six minutes.
Battery Type Life (approx)	9V alkaline 50 Hrs.
Size (LxWxD)	7.8" x 2.5" x 1.8" (19.8 cm x 6.4 cm x 4.6 cm)
Weight (approx)	1.4 lbs (0.64 kg)
Temperature Operating Non-Operating	-20°C to +50°C -20°C to +70°C
Humidity	0% to 90%, Non-Condensing
Accessories Supplied	Shielded Storage Case ^b that holds Meter and 1 or 2 Probes, Battery, Manual, Insulated Handle/Tripod, Model 8713B Electric Field Attenuator, Probe Extension Cable Model 8744-04

^a Not all units of measure can be displayed when used with a limited number of probe models. See *Appendix II*.

^b The heavy duty storage case supplied with the Model 8712 Meter is foam-lined and shielded to protect the meter and probes in storage and in transit. The meter, manual, and up to two probes can be stored in the case. It is approximately 21" x 13" x 6.3" (53 cm x 33 cm x 16 cm).

Table of Contents

8715 SPECIFICATIONS	ii
CHAPTER 1 INTRODUCTION	5
About Your Model 8715	5
Getting Started with the Model 8715	5
Equipment Supplied	6
CHAPTER 2 UNDERSTANDING YOUR MODEL 8712	7
General Description	7
Audio Alarm	7
ATE Test Jack	7
Probe Connection	8
Battery	8
Tripod Mount	9
Insulated Handle / Tripod	9
Electric Field Attenuator	9
Display	10
Keypad	11
Single Function Keys	11
Dual Function Keys	12
CHAPTER 3 PROBE SELECTION	13
Introduction	13
Key Factors in Selecting a Probe	13
Shaped Frequency Response Probes	15
Connecting a Probe	15
CHAPTER 4 MAKING A MEASUREMENT	17
Introduction	17
Getting Started	17
Entering the Probe Measurement Range	17
Entering the Field Type	19
Zeroing the Probe	19
Changing the Probe	21
Units of Measure	21
Maximum Hold	22
Probe Overload and Range Overload	22
Bar Graph Ranges	23
Battery Status Indicator	25

Turning the Meter Off	25
Obtaining a Reading.....	25
Measurement Uncertainty	26
Using Probe Correction Factors.....	27
About Measurement Surveys.....	29
Precautions.....	29
Measurements Below 10 MHz	30
CHAPTER 5 SPATIALLY-AVERAGED MEASUREMENTS	33
Understanding Spatial Averaging	33
Spatial Averaging with the Model 8715	34
Making Spatially-Averaged Measurements	34
CHAPTER 6 TIME-AVERAGED MEASUREMENTS	37
Time-Averaging with the Model 8715.....	37
Making Time-Averaged Measurements	37
CHAPTER 7 SETTING AND USING THE ALARM.....	39
Purpose	39
Alarm Threshold	39
Setting the Alarm	40
CHAPTER 8 MAINTENANCE	43
General.....	43
Calibration	43
Replacement Parts.....	43
Battery	44
APPENDIX II 8700D SERIES PROBES	45
Standard Probe Measurement Ranges	45
Excluded Probe Models	45
Probes Requiring Special Procedures	47
WARRANTY	48
INDEX	49
ABOUT NARDA SAFETY TEST SOLUTIONS	50

Chapter 1

INTRODUCTION

About Your Model 8715

Your Model 8715 is a hand-held, battery-powered meter designed to simplify the measurement of electromagnetic fields. It can be used with any standard Narda 8700 series probes.¹



The meter enables you to perform both simple measurements and more demanding ones that require spatial averaging. It can be mounted on a tripod or used with an insulated handle for enhanced accuracy in certain applications.

Getting Started with the Model 8715

It is important to become familiar with the Model 8715 before you use it. Chapter 2 explains the basic meter hardware. Chapter 3 covers probe selection and Chapter 4 basic operation.

It is strongly recommended that, as a minimum, you read Chapters 2-4, before you attempt to use the Model 8715. The advanced features in Chapters 5, 6 and 7 plus the Appendix can then be referred to as required.

¹ There are a few exceptions and limitations on probes that can be used with the Model 8715. See Appendix *8700D Series Probes* for details.

Equipment Supplied

Your Model 8715 is supplied with

- ◆ Meter
- ◆ Battery, 9 Volt alkaline
- ◆ Storage Case: P/N 32542709
- ◆ Operations Manual
- ◆ Probe Extension Cable: Model 8744-04
- ◆ Electric Field Attenuator: Model 8713B
- ◆ Insulated Handle/Tripod: P/N 21797900

Chapter 2

UNDERSTANDING YOUR MODEL 8715

General Description

It is important to be familiar with the Model 8715 before you use it. This chapter includes descriptive data keyed to highlighted illustrations to help you locate the various features of the meter. The descriptions not only identify the features but tell you how they are used.

Audio Alarm

Your Model 8715 is equipped with an audible alarm that emits sound through a tiny hole on the bottom of the meter. The alarm sounds whenever the field strength exceeds the full scale measurement range of the probe (Probe Overload). It is also used to signify other situations such as certain keystrokes, the completion of the zeroing function, and an over-range condition (which can occur if one of the two more sensitive bar graph ranges is selected). The 8715 can also be set to activate an alarm at a specific field level. See Chapter 7 for details.

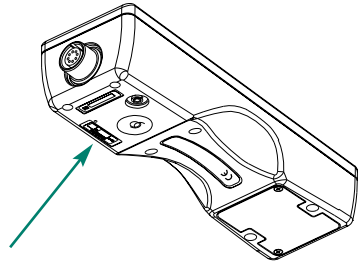

ATE Test Jack

The small jack on the bottom of the meter is used by Narda to calibrate and test the meter using proprietary automatic test equipment (ATE).

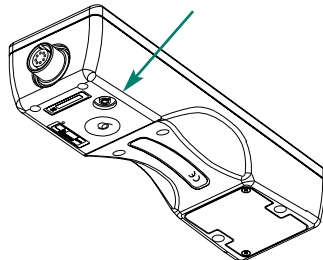

Probe Connection

To make measurements you must connect your Model 8715 to a probe. Normally, the probe is connected to the meter with a cable. The 8700D series probes can be attached directly to the meter. See *Connecting a Probe* in Chapter 3 for details.

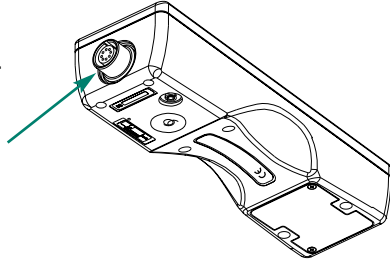

Battery

The 8715 operates for approximately 50 hours from a standard 9 Volt alkaline battery when used an average of two to four hours per day.

The battery is accessed by loosening the two screws on the bottom of the meter and removing the battery cover. See Chapter 8, *Maintenance* for details.

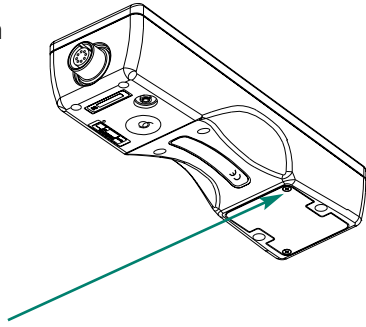

Tripod Mount

The bottom of the 8715 has a standard (1/4-20 NC) tapped hole that can be used to attach the meter to a tripod or to attach a handle.

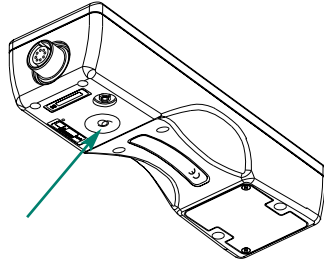

Insulated Handle/Tripod

The 8715 is supplied with an accessory that can be used as either an insulated handle or a small tripod. This unit screws into the tripod mount hole in the bottom of the meter. The rubber face keeps it from rotating once the large knob is tightened. The smaller knob is used to loosen the three legs. The three legs, when parallel to each other, forms an insulated handle. Alternately, the three legs can be positioned to form a small tripod.



Electric Field Attenuator

The Model 8713B electric field attenuator provides a convenient and rapid way to create a "zero" density field for Narda electric field probes. The attenuator is slipped over the head of the probe and closed around the neck of the probe using the hook-and-loop fastener at its opening.



Display

The liquid crystal display (LCD) has a 3¹/₂ digit numerical display, an 18 segment bar graph that indicates relative field strength, eight "arrows" and several special legends. The legends include the units of measure, the words "ZERO", "MAX", and "AUTO", plus a battery status

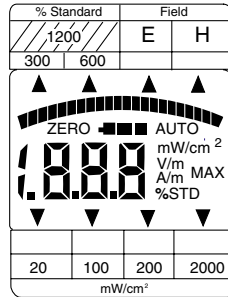

indicator.

Just below the display area are four boxes that indicate four full scale measurement ranges of the 8700 Series flat response probes. Just above the display are four more boxes. The boxes on the left above the display represent the three full scale measurement ranges of 8700 Series shaped frequency response probes. Within each of these boxes is a colored stripe that corresponds to the colored label on 8700 Series probes. For example, probes with a full scale measurement range of 100 mW/cm² have yellow markings. The second box from the left below the display indicates 100 mW/cm² and has a yellow stripe. One arrow will always be illuminated next to one of these boxes to indicate the full scale measurement range the meter is set for.¹

The two boxes above the display on the right indicate whether the electric field or the magnetic field is being measured. One arrow will always be illuminated to indicate what field the meter is set for which should correspond to the type of probe being used.

¹ The 1200% of STD range is indicated with two arrows illuminated (beneath 300 and 600).

Keyboard

The 8715 has eight keys. There are six keys that have a single, dedicated function and two dual function keys.

Single Function Keys

The four yellow keys, the green **On** key and the blue **Off** key all have a single function:

Max Hold Toggles the digital readout between an instantaneous readout and a display of maximum value. (The bar graph continues to function as an instantaneous display.)

Units Changes the unit of measure.

Auto Zero Enables you to automatically zero the meter and probe.

Range Locks in a specific measurement range for the bar graph. **The digital display is not affected.** The meter automatically displays a digital values over the probe's entire measurement range. See *Bar Graph Ranges* in Chapter 4.

On Turns the meter On.

Off Turns the meter Off.

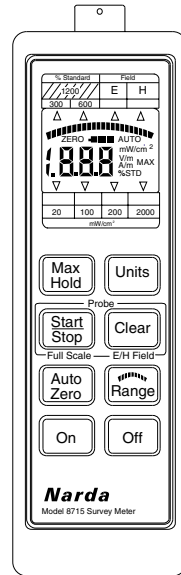

Dual Function Keys

The two white keys each have two functions. Upon turn-on, these two keys are used to set the meter scales to match the probe in use.

Probe Full Scale Used to set the measurement range of the meter to equal the full scale measurement range of the probe.

Probe E/H Field Tells the meter whether an electric field or a magnetic field probe is being used. (This determines what units of measure are available for flat response probes.)

Once the 8715 has been zeroed and is in the measurement mode, these two keys are used to make spatially-averaged measurements.

Start Stop Used to both Start and Stop a spatially-averaged measurement.

Clear Clears the display of a spatially-averaged measurement value and returns the meter to the normal, instantaneous measurement

Chapter 3

PROBE SELECTION

Introduction

The 8700 series system offers a very broad selection of probes. The factors that you should consider in selecting the probe, or probes, best suited for your task and the options for connecting a probe are described in this chapter.

Key Factors in Selecting a Probe

Frequency Range

The probe frequency range should include the frequencies of all the emitters to be surveyed at one time.

Power Density or Field Strength

The measurement range of the probe should be adequate for the field levels that you anticipate. (i.e., Do you expect strong fields or weak fields?) Probes give more accurate and more stable readings when they are not used at the extreme low end of their sensitivity range. Therefore, if you anticipate measuring very weak fields, select a probe with a lower power full-scale measurement range to get greater sensitivity. In contrast, higher power probes give additional safety margins, especially at microwave frequencies where field strength can change rapidly with a small change in distance to the source. Select a probe with higher power full-scale measurement range if you anticipate measuring high level fields.

Electric Field vs. Magnetic Field

Most standards recommend that you measure both electric (E) and magnetic (H) fields below 300 MHz. (Due to the possibility that measurements may be made in the near field.) Since most experts agree that the electric field poses a greater danger at lower frequencies due to induced and contact currents that can occur, the electric field is normally measured first. Higher frequency measurements are normally made of the electric field only since measurements will invariably be made in the far field.

Flat Response or Shaped Response

Flat response probes are the most common. Narda's patented shaped frequency response probes read out in Percent of Standard and are particularly useful in complex, multi-signal environments where exposure limits are different for the various emitter frequencies, and in classified environments.

Size and Minimum Measurement Distance

The majority of the 8700 series probes have four inch (10cm) diameter heads. The minimum measurement distance for these probes is about 4 inch (10 cm) from the outside surface of the probe. Measurements made at closer distances can result in inaccurate readings due to capacitive coupling. The Models 8721, 8723, and 8725 have two-inch (5 cm) diameter heads that can be used as close as 2 inch (5 cm) from the source to the outside of the probe. These probes are ideal for the measurement of **waveguide leaks**. Similarly, the Model 8781 has a one-inch (2.5 cm) diameter head with a flexible shaft that is designed for locating leaks in densely packaged microwave systems.

Shaped Frequency Response Probes

The design and manufacturing goal for a traditional, “flat” frequency response probe is to make the probe equally responsive to energy at every frequency within its rated frequency range. In contrast, Narda’s patented shaped frequency response probes are designed and manufactured so that their sensitivity mirrors a particular standard as closely as possible. For example, many of the major standards in the world set limits for maximum exposure at the lowest frequencies to 100 mW/cm². These same standards typically limit exposure in the VHF region to 1 mW/cm² and to 5-10 mW/cm² in the microwave region. A shaped frequency response probe designed for such a standard is 100 times more sensitive in the VHF Region than at the lowest frequencies. The result is that energy from all sources within the probe's rated frequency range are not only summed in terms of RMS power but are also weighted in direct proportion to a particular standard.

The readout on the 8715 is shown in terms of **Percent of Standard** whenever one of the three % **Standard** ranges is selected to match the probe in use. The full scale of Narda’s shaped probes is either 300%, 600%, or 1200% of a standard. This permits measurements of exposure environments where the weighted field strengths range from as high as three to twelve times the maximum permissible exposure¹ (MPE) level to environments where the levels are less than one percent of the MPE.

¹ It is important to understand that each shaped frequency response probe is designed to conform to a particular standard.

Connecting a Probe

Connect a cable with a quick-release eight pin connector to the connector at the top of your Model 8715.¹ This cable will be either (1) a short adapter cable for attachment to older style 8700 series probes with integral cables or (2) a 4ft./1.2 m long cable with a quick-release connector on both ends for use with the 8700 "D" series probes. The D series probes have a quick-release eight pin connector that allows the probe to attach directly to your 8715 or be used with a cable.

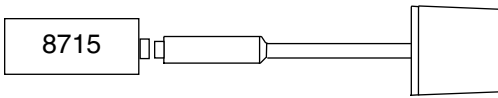

8700D Series Probe
Direct Connection

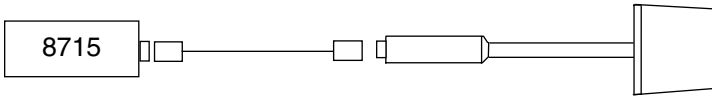

4' (1.2m) cable
Model 8744-04 (supplied) 8700D Series Probe

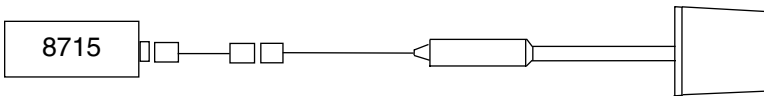

1' (0.3m) adapter cable
P/N 21787700
(Optional Accessory) 8700/8700B Series Probe

A direct connection can be useful for certain low frequency measurements. See *Measurements Below 10 MHz* on page 30.

¹ Ensure probe and/or cable is securely connected to the meter by lightly pulling on the connection.

Chapter 4

MAKING A MEASUREMENT

Introduction

This chapter will help you take measurements with your Model 8715. Information is included for turning the meter on, selecting and zeroing a probe, understanding the display screen, and using the options controlled by the keyboard. Some general information is also included about measurement surveys, precautions you should observe, and the use of probe correction

Getting Started

Press the **ON** key. You will hear a double beep, all LCD segments will turn on briefly and then the version number of the firmware (internal software) will be displayed briefly. After a few seconds, the display screen will show a battery symbol that indicates its status plus a flashing arrow opposite one of the seven probe full scale measurement ranges.

Entering the Probe Measurement Range

The 8700 Series system is completely modular - all 8700 meters work with all 8700 probes¹. ***The single, most important, thing that you must do is to "tell" the Model 8715 the full scale measurement range and the type (electric field or magnetic field) of probe you are using.*** Seven full scale measurement ranges are available. Each range is identified by a colored stripe that should match the colored label on the neck of the probe.

¹ There are a few exceptions and limitations on probes that can be used with the Model 8715. See Appendix, *8700D Series Probes* for details.

Range	Color
20 mW/cm ²	White
100 mW/cm ²	Yellow
200 mW/cm ²	Tan
2000 mW/cm ²	Orange
300% of STD	Medium Blue
600% of STD	Dark Blue
1200% of STD	Dark Blue/White Stripe ¹

The flashing arrow indicates the full scale measurement range of the last probe that was used with the meter.

1. If you want to use the same probe, or another probe with the same full scale measurement range, press the **Probe Full Scale**² key once. The arrow will stop flashing, indicating that the meter has again been set to the same probe measurement range.
2. If you want to use a probe with a different full scale measurement range, press the **Probe Full Scale** key again. Each time you press the probe key the arrow will move to the next probe measurement range. Continue to press the **Probe Full Scale** key until the illuminated arrow points to the full scale measurement range of the probe you intend to use. Alternately, simply hold down the **Probe Full Scale** key and release it when the arrow indicating the correct measurement range is illuminated.

¹ The 1200% of Standard range is indicated with two arrows illuminated.

² A few special probes have full scale measurement ranges other than the seven ranges on the 8715. Refer to the Appendix if you want to use one of these probes with your 8715.

Entering the Field Type

Once the full scale measurement range of the probe has been selected, another flashing arrow will appear that indicates the field type of the probe last used with the meter.

1. If you want to use the same probe, or another probe that measures the same field, press the **Probe E/H Field** key once. The arrow will stop flashing indicating that the meter has again been set to work with a probe that measures the same field, either electric or magnetic, as before.
2. If you want to use a probe with a different field, press the **Probe E/H Field** key again. Each time you press the **Probe E/H Field** key the arrow will move back and forth between electric field and magnetic field. Continue to press the **Probe E/H Field** key until the arrow below the field type of the probe you intend to use is illuminated.
3. The word **ZERO** will flash slowly on the display.

Zeroing the Probe

The probe and meter must be "zeroed" together. It is important that the probe is not exposed to radiated fields during the zeroing process. The storage case is shielded and provides a convenient "zero density" environment. Alternately, the Model 8713B Electric Field Attenuator can be used to zero electric field probes. It is also important the meter and the probe be zeroed when both are at the same temperature.

To zero the probe...

1. Place the probe in the storage case or cover the probe with the model 8713B. Be careful not to move the probe while zeroing takes place. (On probes with low frequency test points you can create static which will give inaccurate results.)

2. When you are ready, press the **Auto Zero** key. The internal temperature of the meter is displayed briefly. The word **ZERO** will be displayed. The zeroing process takes about four seconds.
3. After zeroing is completed, the audio alarm will "beep" once and the measurement screen will appear. You will see a digital display with a unit of measure. Depending on the probe and the intensity of the field, you may also see some deflection on the bar graph.

If the probe cannot be zeroed, the word **ZERO** will flash and the audio alarm will beep several times. The most likely reasons why the probe could not be zeroed are:

- ◆ *The probe is not connected properly.* Check the connector and retry.
- ◆ *The field strength is not low enough.* Move away from the antenna and use the storage case to zero the probe.
- ◆ *The probe is damaged.* Try another probe.

To reconfirm the zero while the instrument is in use...

1. Establish a zero density environment for the probe as before.
2. Press the **Auto Zero** key for about one-half second (until you hear two beeps). This will automatically "touch up" the zero and correct for any drift in about four seconds. This slight delay (in the operation of the **Auto Zero** key) occurs only after the meter and probe have been zeroed the first time. The delay is designed to prevent the meter from accidentally being taken out of the measurement mode.

Changing the Probe

Once the meter and probe have been successfully zeroed, the two white dual function keys change function for use with spatially-averaged measurements. If you want to change to another probe, you must shut off the meter and repeat the turn-on procedure described at the beginning of this chapter. The two white dual function keys then revert back to functioning as the **Probe Full Scale** and the **Probe E/H Field** keys so that the meter can be set to match the characteristics of the new probe.

Units of Measure

The **Units** key is used to change the units of measure. Only units of measure appropriate to the probe are available, providing, of course, that you have correctly set the probe measurement range and the field type (electric or magnetic) for the probe you are using.

The meter is set to read in mW/cm^2 upon turn-on if a flat response probe range (Probes rated in mW/cm^2) has been selected. The **Units** key is used to cycle through the available options. Press the **Units** key once to get W/m^2 . Press it again to get either V/m (electric field probes) or A/m (magnetic field probes).

Shaped response probes (rated in % of STD) can only be used to read out in Percent of Standard. The **Units** key is inoperative when using these probes.

Maximum Hold

The maximum hold feature changes the digital readout to a display of maximum value. The bar graph continues to function as an instantaneous display. Use the **Range** key to control the operation of the bar graph (see *Bar Graph Ranges*)

Press the **Max Hold** key to activate the maximum hold feature. The legend **MAX** will illuminate on the display to the right of the units of measure.

Press the **Max Hold** key again to release the maximum hold feature and return to the normal, instantaneous measurement mode. This also clears the maximum hold value.

Probe Overload and Range Overload

The Model 8715 is designed to protect the probe and the operator from very high fields by providing a warning when either the full scale measurement range of the probe is exceeded and/or one of the fixed bar graph ranges is exceeded. See *Bar Graph Ranges*.

A "Probe Overload" is indicated by the continuous sound of the audio alarm and the digital display flashing "**O-L**" (**OverLoad**).

A "Range Overload" can occur when the bar graph is set to one of the two more sensitive ranges. Under these conditions the digital display continues to show a correct value while the bar graph is fully illuminated. The audio alarm beeps twice whenever the range of the bar graph is first exceeded. See *Bar Graph Ranges*.

Bar Graph Ranges

The bar graph has 18 divisions. The **Range** key is used to control how the bar graph displays information. The **digital display is not affected** and the meter automatically displays a digital value over the probe's entire measurement range. There are four available bar graph range settings: **AUTO** and three fixed ranges.

The default setting upon turn on is the **AUTO** range which you will probably find convenient to use most of the time. Under a few conditions you may find one of the three fixed ranges useful. The following table illustrates how the range setting will affect the bar graph. For simplicity, *a probe with a full scale rating of 100 mW/cm² is used as an example.*

Range	Measurement Range
AUTO	As the level increases the bar graph automatically switches between three ranges: 0.1 to 1, 1 to 10, and 10 to 100 mW/cm ²
HIGH	10 to 100
MID	1 to 10
LOW	0.1 to 1

If W/m² is selected as the unit of measure, the meter will operate in a similar manner. The only difference is that the ranges will be ten times higher (1 mW/cm² = 10 W/m²).

The Range key is not functional when either V/m or A/m is selected as the unit of measure. For example the bar graph has a single fixed range of 0-614 V/m or 0-1.63 A/m for a 100 mW/cm² probe.

To determine the current bar graph range setting...

1. Press and release the **Range** key. The measurement screen will disappear. If the meter is in the automatic range mode, the legend **AUTO** illuminates. If the meter is set to one of the fixed ranges, the screen shows either **100%**, **10%**, or **1%** for flat response probes. Shaped response probes are defined in terms of percent of standard. The fixed ranges for shaped probes are either **300% STD**, **30% STD** and **3% STD** or **600% STD**, **60% STD** and **6% STD**, or **1200% STD**, **120% STD** and **12% STD**, depending on the full scale measurement range of the probe.
2. If the range setting is correct, simply wait about 1¹/₂ seconds and the measurement screen will reappear.

To change range settings...

1. Press the **Range** key. The measurement screen will disappear and the screen will display the current range setting.
2. Press the **Range** key again before the measurement screen reappears (within five seconds). A new range will be displayed. Continue to press the **Range** key until you get the desired bar graph range.
3. About 1¹/₂ seconds after the last key stroke, the measurement screen will reappear.

Battery Status Indicator

The battery status indicator consists of three sections that form the shape of a typical battery. The number of battery sections that are illuminated indicate how "full" the battery is. This is only a relative indication that should be compared to the expected life of the battery which varies with the average use time. The relative remaining battery capacity is:

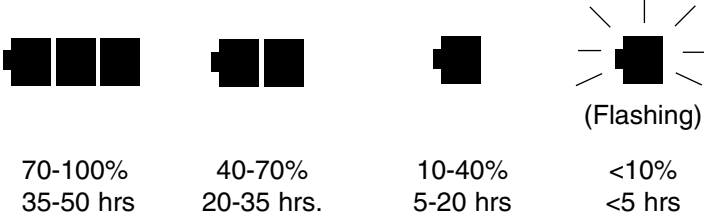

When the indicator has decreased to one segment in length and begins to flash, the battery has about 10% of its life remaining and should be replaced as soon as possible.

Turning the Meter Off

The meter is turned off by pressing the **Off** key and holding it down for about half a second (The delay is built in to minimize the chance of the operator accidentally turning the meter off).

Obtaining a Reading

A reading is obtained by holding your Model 8715 in one hand and your probe in the other. As you approach the source, observe the bar graph and measured value of signal strength on your meter. If you know where the source of energy is, point the probe towards it. If you do not know where the source is located or there are multiple sources, hold the probe above your head pointed up at about 45 degrees above the horizontal. Rotate the probe in a circle to find the direction where the maximum indication is obtained. The bar graph is a useful tool in obtaining the maximum indication.

Measurement Uncertainty

The *uncertainty* of any measurement includes several factors:

- ◆ Frequency response or frequency sensitivity is typically ± 1 dB to ± 2 dB (about $\pm 22\%$ to about $\pm 50\%$). The correct use of correction factors (See *Using Probe Correction Factors*) can greatly reduce the amount of uncertainty associated with frequency response.
- ◆ Ellipse ratio is ± 0.75 dB or better, depending on the model of the probe. The ellipse ratio is the ratio of readings that occur when one rotates the probe around the axis of its handle. Narda calibrates its probes by rotating the probe about its axis and using the mean value for the correction factor. If you rotate the probe around its axis and use the mean value, ellipse ratio can be eliminated as a source of uncertainty.
- ◆ Isotropic response is the error that occurs when the probe is pointed in different directions. It includes the ellipse ratio plus some additional uncertainties. Although the probes pick up energy from all directions, they are most accurate when pointed at the source of energy. In general, the isotropic response is no greater than the ellipse ratio providing that the probe is pointed towards the source.
- ◆ Calibration uncertainty represents another 0.5 dB.
- ◆ The Model 8715 meter is accurate within $\pm 3\%$.

A good rule of thumb is that the total uncertainty is no greater than ± 3 dB when correction factors are not used providing that the probe is pointed at the source of energy.

Using Probe Correction Factors

All probes have a certain amount of *frequency sensitivity*. Frequency sensitivity is the amount of deviation from the correct measured value that a probe yields at various frequencies. Obviously, the smaller the deviation, the better. But since a certain amount of frequency deviation is unavoidable, the more frequencies that you calibrate the probe at, the better. At each calibration frequency, you have a correction factor.

Multiplying the reading on the meter by a correction factor marked on the handle of a Narda 8700 Series probe compensates for the probes frequency sensitivity. For example, if a probe reads 10% too high at a particular calibration frequency, the correction factor marked on the probe handle will be 0.91. Multiplying a reading that indicates 110% by 0.91 yields an corrected reading of 99.9% – essentially compensating for the probes frequency deviation. Similarly, a probe that reads 10% low at a particular calibration frequency will have a correction factor of 1.11 marked on the handle.

Correction factors can be used:

- ◆ When there is only a single emitter being surveyed.
- ◆ When there are multiple emitters all operating at the same frequency (this is often the case with industrial equipment).
- ◆ When there are multiple emitters with frequencies that are close to each other and the nearest calibration frequencies have very similar correction factors.

Correction factors can **NOT** be used:

- ◆ When the frequencies of the emitters are diverse. Correction factors may vary considerably and there is no way to determine the distribution of energy from the various emitters. It is more accurate not to use a correction factor under these conditions. See *Measurement Uncertainty on the previous page*.

To use a correction factor...

1. Make a measurement in the normal manner.
2. Compare the frequency of the emitter that you are surveying to the calibration frequencies marked on the handle of the probe that you are using. If the frequencies are no more than 10% apart, simply multiply reading displayed on the meter by the correction factor at that calibration frequency.
3. If the difference between the emitter frequency and the nearest calibration frequency is more than 10% of the emitter frequency, make a linear interpolation to establish a correction factor. In other words, use the two calibration frequencies closest to the emitter – one higher and one lower – and calculate the correction factor at the frequency of the emitter. Multiply the reading on the meter by this calculated correction factor to obtain a more precise measurement.¹

CAUTION

If the two correction factors are vastly different (which can happen near the upper or lower limit of the probe's frequency range) the interpolation can yield uncertain results and may not significantly reduce the measurement uncertainty.

¹ If you are displaying field levels in either V/m or A/m, you should multiply the reading by the *square root* of the factor indicated on the probe.

About Measurement Surveys

When you perform surveys it is important that you observe a few guidelines to insure accurate readings:

- ◆ Make sure you move the probe to obtain a maximum reading.
- ◆ Keep the arm holding the probe extended out from your body as far as possible with the probe pointed towards the source of radiation.
- ◆ Low frequency measurements (<10 MHz and especially <2 MHz) require special techniques because the human body acts as an antenna and introduces errors. See *Measurements Below 10 MHz on the following page*.

The human body has far less effect on magnetic fields. Therefore these measurement techniques are less critical for magnetic fields than they are for electric fields.

Precautions

When making measurements of electromagnetic fields, a potential exists to expose yourself to excessive levels of RF energy. Approach the source of energy slowly and begin making measurements from a distance that is known to have low levels present. ***Be prepared to evacuate the area immediately if excessively high levels are observed.***

Measurements Below 10 MHz

It is not simple to make accurate measurements of the electric field below 10 MHz. At these low frequencies, the human body not only interacts with the electric field but the measurements are affected as well.

Measurement errors can occur for two reasons – and both result in readings that are significantly higher than the actual field strength.

1. If the meter and probe are physically separated, they could be measuring a scalar effect rather than a vector RF field. To guard against this occurrence, do not use the probe extension cable connect the probe directly to the meter. If you are still experiencing high readings that do not seem correct, you should check to see whether the meter is responding to an actual RF force field or if it is reacting to the scalar effect.

To do this, simply use the Model 8713B Electric Field Attenuator to shield the probe. Make sure that you close the opening around the neck of the probe using the hook-and-loop fastener inside the attenuator. If the reading remains about the same with the attenuator in place, the meter is measuring a scalar field and yielding an incorrect, high value.

If the meter reading drops to close to zero, then the probe was correctly responding to an actual RF force field. You may "touch up" the zero at this point by pressing the **Auto Zero** key. Then, remove the electric field attenuator and proceed to make measurements.

2. At these low frequencies the human body can become part of the measurement circuit. The body of the 8715 meter is aluminum to provide strength and electrical shielding. The one disadvantage of this construction is that the meter makes good electrical contact with the body via your hand. This will normally result in higher than actual readings—typically double the correct value. The insulated tripod/handle screws into the bottom of the meter. Even when used as a handle, this small separation significantly reduces the interaction between the meter and your body. Alternately, this accessory can be used as a tripod. The meter, probe, and tripod can then be set down on a non-metallic stand such as a ladder or a cardboard box. Then stand back and read the meter without touching it.

The human body has far less effect on magnetic fields. Therefore these measurement techniques are less critical for magnetic fields than they are for electric fields.

Chapter 5

SPATIALLY-AVERAGED MEASUREMENTS

Understanding Spatial-Averaging

The major standards concerned with human exposure to radio frequency radiation specify maximum exposure levels averaged over the whole body. The co-linear dipole antenna arrays that are very common in modern wireless communications systems, for example, have multiple lobes close to the antenna. The field strength typically varies by 6-7 dB along the length of an array. Therefore, the measured value is highly dependent on not only the distance from the antenna but the height above the ground.

The traditional method of making spatially-averaged measurements is to use a "storypole". A storypole is a non-conductive pole, often wooden, equal in height to an average adult with distance marks equally spaced along its length. Measurements are made alongside the storypole at each height and then mathematically averaged. The height and spacing of each measurement varies from standard-to-standard. For example, the IEEE C95.1-1991 standard specifies measurements from 20 centimeters (about 8 inches) to 200 centimeters in 20 centimeter increments. Some exposure standards, such as Canada's Safety Code 6, require that measurements be averaged across two dimensions – vertically and horizontally. Modern wireless communications sites make this manual technique more difficult than ever since field levels at many sites, particularly multi-user sites, are constantly varying. For example, paging systems go on and off and the number of cellular channels in use is constantly changing. Thus, a series of measurements made at varying heights can vary both as a function of time and of location.

Spatial Averaging with the Model 8715

The Model 8715 can be used to make precise, spatially-averaged measurements. The meter averages 40 measurements per second while the probe is moved at a uniform rate of speed.

Once the meter and probe have been successfully zeroed, the two white dual function keys change function for use with spatially averaged measurements. Press the **Start/Stop** key to start the timer. Pressing the same key again stops the timer. During this interval of time, the meter takes a large number of measurements. The results are presented as an average value. Effective measurement technique requires you to simply move the probe slowly from toe-to-head while the timer is running. Although this technique may not be specifically called out in a particular exposure standard, it is technically a very sound and much more accurate method than averaging a series of measurements. It is anticipated that future updates of the major standards will reflect this automatic technique now that the survey equipment makes it practical.

Making Spatially-Averaged Measurements

To make spatially-averaged measurements...

1. Make sure that the meter and probe have been successfully zeroed and the meter is indicating instantaneous field strength readings.
2. Holding the meter in one hand and the probe in the other, touch the head of the probe to the ground.
3. Press the **Start/Stop** key to start the timer (The meter will sound a single “beep”) while slowly moving the probe vertically *at a constant rate of movement*.¹ (The maximum hold mode will automatically shut off when you begin to make a spatially-averaged measurement).
4. Strive for an interval of about ten seconds between starting and stopping the timer.

5. When the probe reaches the height equal to the top of an adult's head (about 6 ft./1.9 m), press the **Start/Stop** key to stop the timer.² The meter will sound a long “beep.”
6. The meter will display the average value.
7. To make another spatially averaged measurement, first press the **Clear** key. Then press the **Start/Stop** key again to begin a new spatially-averaged measurement.
8. To return to making real time measurements, press the **Clear** key.

¹ It is important to move the probe vertically at a constant rate to obtain an accurate average value.

² The maximum averaging interval is 20 seconds. If the **Start/Stop** key is not pressed within 20 seconds, the meter will beep three times signifying automatic termination of the measurement interval. The 8715 displays the average value obtained over the 20 second interval.

Chapter 6

TIME-AVERAGED MEASUREMENTS

Time-Averaging with the Model 8715

The Model 8715 can be used to make precise, time-averaged measurements for any period up to six minutes. The meter averages 50 measurements per second. For periods up to forty seconds there is a 0.2-second resolution in terms of stopping the averaging. Averaging periods from >40 seconds to <six minutes have a two-second resolution i.e. if the **Start/Stop** key is pushed after 79.5 seconds, the average value will be based on 78.0 seconds. The resolution is 0.2-seconds if the meter is allowed to stop averaging after six minutes. Time-averaged measurements are made using the same meter controls used in spatially averaged measurements.

Making Time-Averaged Measurements

To make time-averaged measurements...

1. Make sure the meter and probe have been successfully zeroed and the meter is indicating instantaneous field strength readings.
2. Position the probe where you want to make the measurement.
3. Press the **Start/Stop** key to start the time. The meter will sound a single "beep".
4. Press the **Start/Stop** key a second time to end the time-averaged measurement. The meter displays the average value at the end of the averaging period and will continue to display it until the **Clear** key is pressed or the meter is shut off. Pressing the **Clear** key returns the meter to the real-time measurement mode.
5. Time averaging ends automatically after six minutes if you do not press the **Start/Stop** key a second time. To signify this automatic shut-off, the meter will beep three times.

Chapter 7

SETTING AND USING THE ALARM

Purpose

The 8715 activates a continuous audio alarm whenever the full scale measurement range of the *probe* is exceeded. This helps protect the probe from damage that could occur if exposed to fields far above its measurement range. An alarm can be set by the user, or the safety program administrator, to help *protect the user* from exposure to strong RF fields.

Alarm Threshold

The alarm can be set from 1% to 100% of the *probes full scale measurement range*. It is important to know the measurement range of the probe that will be used in order to calculate where to set the alarm threshold. For example, setting the alarm to "25%" will result in the alarm sounding at a level of 5 mW/cm² for a probe with a full scale measurement range of 20 mW/cm². However, if the user changes to a 100 mW/cm² probe, the alarm will sound at a level of 25 mW/cm².

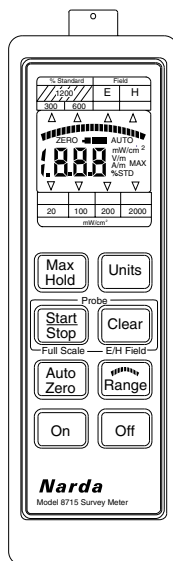

When using a shaped probe, it is often desirable to have an alarm sound at 50% of standard. This allows for 3 dB of measurement uncertainty (See *Measurement Uncertainty* on page 26) and helps prevent the user from entering an area with field levels that are potentially above the standard that the probe is shaped to. To set the alarm to sound at approximately 50% of standard, set the alarm to 17% for a probe rated at 300% of standard and at 8% for a probe rated at 600% of standard.

Setting the Alarm

To set the alarm threshold...

1. Press the **ON** power key. You will hear a double beep, all LCD segments will turn on briefly and then the version number of the firmware (internal software) will be displayed briefly. After a few seconds, the display screen will show a battery symbol that indicates its status plus a flashing arrow opposite one of the six probe full scale measurement ranges.
2. Depress both the **Max Hold** and the **Units** keys at the same time. The letters "AL" will be displayed on the LCD. When the keys are released, the current alarm threshold setting will be displayed as a numeric value from 1% to 100%.
3. To increase the alarm threshold to a higher percentage, press the **Units** key. If the **Probe E/H Field** key is depressed at the same time, the alarm threshold will increase in increments of ten percent instead of increments of one percent.
4. To decrease the alarm threshold to a lower percentage, press the **Range** key. If the **Probe E/H Field** key is depressed at the same time, the alarm threshold will decrease in increments of ten percent instead of increments of one percent.
5. When the alarm threshold is set to the desired level, press the **Probe Full Scale** key to accept the setting and to continue with the normal meter turn-on procedure (See *Entering the Probe Measurement Range* on page 17).

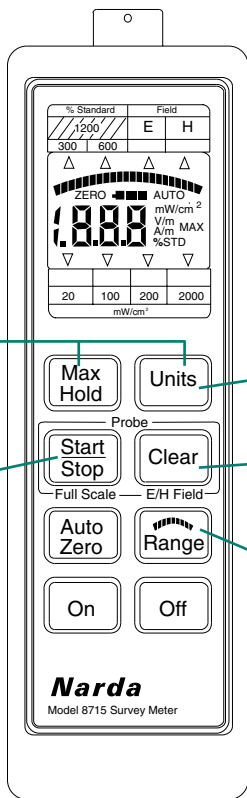

Press to Access Alarm Setting Mode

Save the Alarm Threshold Setting

Increases Alarm Threshold

Increases or Decreases Alarm Threshold in 10 % Increments

Decreases Alarm Threshold

Chapter 8

MAINTENANCE

General

The Model 8715 requires very little maintenance. No operator adjustments are required. The electronic circuitry is housed in a very rugged aluminum housing. However, this housing is not watertight and should not be immersed in water. The LCD display and the case may be cleaned using a damp cloth. Do not use any type of detergent or solvent.

Calibration

The Model 8715 is calibrated before it is shipped. Narda recommends that the Model 8715 be calibrated annually. Narda will perform this calibration for a nominal charge.

Replacement Parts

Item	Model or Part Number
Storage Case	P/N 32542709
Probe Extension Cable	Model 8744-04
Electric Field Attenuator	Model 8713B
Insulated Handle/Tripod	P/N 21797900

Battery

A standard 9 volt alkaline battery will power the 8715 meter for approximately 50 hours when used an average of two to four hours per day. The three section battery status indicator gets shorter as the battery's energy is used. When the indicator has decreased to one segment in length and begins to flash, the battery has about 10% of its life remaining and should be replaced as soon as possible.

The battery is located in a compartment in the lower part of the back of the meter. The battery compartment cover is held in place with two small screws that are captive to the cover. To replace the battery...

1. Loosen the two screws and remove the cover.
2. Remove the battery and disconnect the battery clip.
3. Connect the new battery and place it in the compartment.

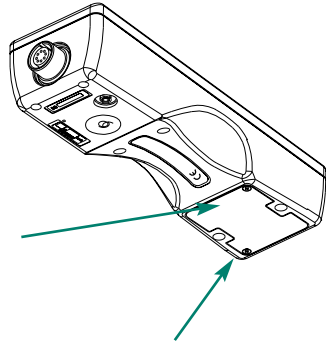

4. Replace the cover and tighten the two screws.

Any standard 9 volt alkaline battery can be used. Two examples are the Eveready No. 522 and the Duracell DA146.

Appendix

8700D SERIES PROBES

Standard Probe Measurement Ranges

The seven full scale measurement ranges (four for flat response probes and three for shaped response probes) available on the 8715 represent the most common probes in the 8700D Series. A limited number of probes with other full scale measurement ranges have been produced in the past and new probe models may be offered in the future. These models are identified in the table on the next page. They require special measurement procedures.

Excluded Probe Models

A limited number of "E" series probes - probes with an E prefix in the model number - were supplied for Electromagnetic Compatibility (EMC) applications. These probes are all rated in Volts per meter (V/m). None of the six scales on the 8715 are directly equivalent to these E series probes. Therefore, **probes rated in volts per meter should not be used with the 8715.**

8700D Series Probes

Model	Field	Frequency Range	Full Scale Measurement Range	Color Code	Special Procedure Applicable
8782D	E	3 kHz to 1 MHz	200 mW/cm ²	Tan	No
8764D		100 kHz to 300 MHz			
8760D		300 kHz to 3 GHz	100 μW/cm ²	Yellow	Yes
8761D			20 mW/cm ²	White	No
8762D			200 mW/cm ²	Tan	
A8742D			600% of Standard	Dark Blue	
B8742D					
8741D		300 kHz to 50 GHz	20 mW/cm ²	White	
A8722D			300% of Standard	Light Blue	
B8722D					
C8722D					
D8722D					
8721D		300 MHz to 50 GHz	20 mW/cm ²	White	
8723D			100 mW/cm ²	Yellow	
8783D					
8725D		1 GHz to 40 GHz	1000 mW/cm ²		Yes
8781D		2 GHz to 18 GHz	20 mW/cm ²	White	No
8752D		300 kHz to 10 MHz	200 mW/cm ²	Tan	
8754D	2 W/cm ²		Orange		
8732D	300 kHz to 200 MHz	300% of Standard	Light Blue		
8731D	10 MHz to 300 MHz	20 mW/cm ²	White		
8733D		100 mW/cm ²	Yellow		

Probes Requiring Special Procedures

The 8700 Series probes that have full scale measurement ranges different from the ranges on the 8715 are (currently) flat response probes rated for either extremely low field strengths or extremely high field strengths. These probes can be used with the 8715 meter. **The major restriction is that the field strength units of measure (V/m and A/m) cannot be used.** This is because a linear relationship is maintained with units of equivalent power density but a square root calculation is used to convert to field strength.

The following table shows how these probes should be used:

Model	Rating	Meter Range	Meter Units	Comments
8760	20 $\mu\text{W}/\text{cm}^2$	20 mW/cm^2	mW/cm^2	Read as $\mu\text{W}/\text{cm}^2$ instead of mW/cm^2
8760D	100 $\mu\text{W}/\text{cm}^2$	100 mW/cm^2	mW/cm^2	Read as $\mu\text{W}/\text{cm}^2$ instead of mW/cm^2
8725 & 8725D	1000 mW/cm^2	100 mW/cm^2	W/m^2	Read as mW/cm^2 instead of W/cm^2

Note

To obtain a reading in V/m using the Model 8760D probe:

1. Set the 8715 meter to the 100 mW/cm^2 (yellow bar) range
2. Read the value shown on the display except interpret the results in $\mu\text{W}/\text{cm}^2$
3. Manually convert the value in $\mu\text{W}/\text{cm}^2$ to V/m using the formula

$$\sqrt{\mu\text{W}/\text{cm}^2 \times 3.77} = \text{V/m}$$

Example:

$$100 \mu\text{W}/\text{cm}^2 = \sqrt{100 \times 3.77} = 19.4 \text{ V/m}$$

Warranty

Narda Safety Test Solutions (Narda STS) warrants each product of its manufacture to be free from any defect in material and workmanship for a period of one year from date of shipment to, and return by, the original purchaser. All warranty returns, however, must first be authorized by a factory office representative.

The limit of liability under this warranty shall be to repair or replace any product, or part thereof, which proves to be defective after inspection by Narda STS. This warranty shall not apply to any Narda STS product that has been disassembled, modified, physically or electrically damaged or any product that has been subjected to conditions exceeding the applicable specifications or ratings.

Narda STS shall not be liable for any direct or consequential injury, loss or damage incurred through the use, or the inability to use, any Narda STS product.

Narda STS reserves the right to make design changes to any Narda STS product without incurring any obligation to make the same changes to previously purchased units.

This warranty is the full extent of obligation and liability assumed by Narda STS with respect to any and all Narda STS products. Narda STS neither makes, nor authorizes any person to make, any other guarantee or warranty concerning Narda STS products.

Index

- Alarm, Audio
 - Description, 7
 - Setting, 39-41
 - Threshold, 39
- ATE Test Jack, 7
- Auto Zero**, key
 - Description, 11
 - Using, 19, 20
- Battery
 - Changing, 44
 - Status Indicator, 25
 - Type, 9, 44
- Calibration, 43
- Clear**, key
 - Description, 12
 - Using, 34, 35
- Correction Factors, Probe, 27
- Display (LCD), 10
- Electric Field, 11
- Electric Field Attenuator
 - Description, 9
 - Using, 19
- Equipment, 6
- Field Strength, 13, 45
- Insulated Handle/Tripod
 - Description, 9
 - Using, 9, 31
- Keypad, 11
- Magnetic Field, 13
- Max Hold**, key
 - Description, 11
 - Using, 22
- Off**, key
 - Description, 11
 - Using, 25
- On**, key
 - Description, 11
 - Using, 17
- Maintenance, 43
- Power Density, 13, 47
- Probe
 - Changing, 21
 - Connection, 8, 16
 - Correction Factors, 27-28
 - E Series, 46
 - Field Type, Entering, 19
 - Key, Description, 11, 12
 - Measurement Range
 - Entering, 17, 45
 - Overload, 22
 - Selection, 13
 - Zeroing, 19
- Probe Full Scale**, key, 12
- Probe E/H Field**, key
 - Description, 12
 - Using, 19
- Range**, key
 - Description, 11
 - Using, 23
- Ranges
 - Bar Graph, 23
 - Probe Measurement, 17, 45
 - Probe Overload, 22
- Shaped Response, Probe, 14, 15
- Spatial-Averaging
 - Description, 33, 34
 - Measurements, 34, 35
- Start/Stop**, key
 - Description, 12
 - Using, 34, 35
- Surveys
 - Measurement, 29
 - Measurement Uncertainty, 26
 - Obtaining a Reading, 25
 - Precautions, 29
- Time-Averaging
 - Description, 37
 - Measurements, 37
- Units**, key
 - Description, 11
 - Using, 21

About Narda Safety Test Solutions

Narda Safety Test Solutions is the new name for the world leader in non-ionizing radiation safety equipment. In February 2000, Narda – an L-3 Communications Company – acquired the Safety Test Solutions business from Wavetek Wandel & Goltermann. To give more focus to the RF safety business and to separate it from Narda's other business in components and networks, a new division was formed – Narda Safety Test Solutions. It combines the complementary product lines and expertise of these two businesses. The company holds more than 95% of the patents in the field. Products are available to accurately measure electromagnetic fields from a few Hertz to over 100 GHz plus static magnetic fields. RF personal monitors cover 100 kHz to 100 GHz and area monitors detect energy from 300 kHz to 100 GHz.



USA: 435 Moreland Road
Hauppauge, NY 11788
Tel 1-631 231-1700 **Fax** 1-631 231-1711
E-Mail NardaSTS@L-3COM.com
www.narda-sts.com

GERMANY: Sandwiesenstrasse 7
D-72793 Pfullingen
Tel +49-7121-9732-777 **Fax** +49-7121-9732-790
E-Mail support@narda-sts.de
www.narda-sts.de